

MARKING TOOLS & MACHINES

INTERCHANGEABLE STEEL TYPES

- Perfect for part-numbering and specification marking on steel, aluminium, brass, etc.
- High tool life. Reduces production downtime.
- Types made from high quality tool steel: treated to remove scale and resist rust.
- Hardened and tempered for high wear resistance, retaining roughness at the same time.
- All dimensions to very close tolerances, for the clearest uniform impression when several types are assembled together.
- Composite stamping by assembling types in holders for hand or machine stamping.

STANDARD FOUNT SETS

- Types are available in standard fount sets in sizes ranging from 1mm to 10mm.
- Comprise, alphas, numerals and punctuation marks selected to cover most needs and minimise duplication.
- Fount sets for smaller type sizes consist of **100 TYPES COMBINATION** while those for the bigger type sizes consist of **60 TYPES COMBINATION**.
- Sets are available with or without hand & machine holder as desired, in a compact wooden box with tweezers for the smaller sizes.



RANGE OF TYPE SIZE

TYPE CODE NO.	CHARACTER SIZE D MM	TYPE SIZE			FOUNT SET CODE NO.		NUMBER OF TYPES IN SET	NUMBER OF SPACERS IN SET	HAND HOLDER CODE NUMBER	HAND HOLDER HOLDING CAPACITY
		A MM	B MM	C MM	WITH HAND HOLDER	WITHOUT HAND HOLDER				
T010	1.00	1.00	8.00	25.00	112 EH 010	112 E 010	100	12	8 EH 20	20
T062	1.59 (1/16")	1.59	3.18	15.88	112 EH 062	112 E 062	100	12	125 EH 750	12
T020	2.00	2.00	8.00	25.00	112 EH 020	112 E 020	100	12	8 EH 25	12
T093	2.40 (3/32")	2.40	6.35	19.05	112 EH 093	112 E 093	100	12	250 EH 1000	10
T030	3.00	3.00	8.00	25.00	112 EH 030	112 E 030	100	12	8EH 25	8
T125	3.18 (1/8")	3.18	6.35	19.05	112 EH 125	112 E 125	100	12	250 EH 1250	10
T040	4.00	4.00	8.00	25.00	112 EH 040	112 E 040	100	12	8 EH 040	10
T187	4.76 (3/16")	4.76	7.94	19.05	112 EH 187	112 E 187	100	12	312 EH 1250	6
T050	5.00	5.00	8.00	25.00	112 EH 050	112 E 050	100	12	8 EH 40	8
T060	6.00	6.00	8.00	25.00	112 EH 060	112 E 060	100	12	8 EH 40	6
T250	6.35 (1/4")	6.35	9.53	19.05	112 EH 250	112 E 250	100	12	375 EH 2250	6
T080	8.00	8.00	14.00	25.00	66 EH 080	66 E 080	60	6	14 EH 60	7
T375	9.53 (3/8")	9.53	15.88	25.40	66 EH 375	66 E 375	60	6	625 EH 2250	6
T100	10.00	10.00	14.00	25.00	66 EH 100	66 E 100	60	6	14 EH 60	6

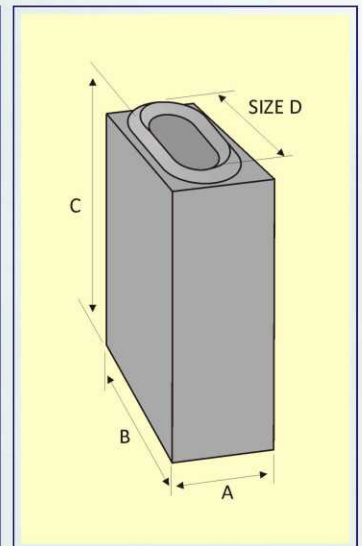

COMBINATION OF 100 TYPES

A	A	A	B	B	C	C	D	D	E	E	E	E	F	F	G	G	H	H	I
I	I	J	J	K	K	L	L	L	M	M	N	N	N	O	O	O	P	P	Q
R	R	R	S	S	S	T	T	U	U	U	V	W	W	X	X	Y	Z	&	/
/	-	-	1	1	1	1	2	2	2	2	3	3	3	4	4
4	4	5	5	5	6	6	6	7	7	7	8	8	8	9	9	9	0	0	0
<input type="checkbox"/>	<input type="checkbox"/>	<input type="checkbox"/>	<input type="checkbox"/>	<input type="checkbox"/>	<input type="checkbox"/>	<input type="checkbox"/>	<input type="checkbox"/>	<input type="checkbox"/>	<input type="checkbox"/>	<input type="checkbox"/>	<input type="checkbox"/>	<input type="checkbox"/>	<input type="checkbox"/>	<input type="checkbox"/>	<input type="checkbox"/>	<input type="checkbox"/>	<input type="checkbox"/>	<input type="checkbox"/>	<input type="checkbox"/>

COMBINATION OF 60 TYPES

A	B	C	D	E	F	G	H	I	J	K	L	M	N	O
P	Q	R	S	T	U	V	W	X	Y	Z	1	1	1	2
2	2	3	3	3	4	4	4	5	5	5	6	6	6	7
7	7	8	8	8	9	9	9	0	0	0	/	-	.	.
<input type="checkbox"/>	<input type="checkbox"/>	<input type="checkbox"/>	<input type="checkbox"/>	<input type="checkbox"/>	<input type="checkbox"/>	<input type="checkbox"/>	<input type="checkbox"/>	<input type="checkbox"/>	<input type="checkbox"/>	<input type="checkbox"/>	<input type="checkbox"/>	<input type="checkbox"/>	<input type="checkbox"/>	<input type="checkbox"/>

* THIS TYPES IS SPACER
Other combination available

SPECIAL TYPES ALSO AVAILABLE

- Segment, radial, grooved and stepped types for Special applications.
- Dotted calligraphy/Low stress types.
- Convex/Concave character faces.
- Special materials for types to suit the applications.
- Types for red-hot stamping.
- Types for hot-foil stamping.
- Types for different kinds of packaging : Card board, Collapsible Tube Crimping, Sachets, Tetrapacks etc.